

PARÇA KODU PART CODE	PARÇA ADI PART NAME	ERKEK TERMİNAL MALE TERMINAL	a ÖLÇÜSÜ (AYAR) a MEASURE (SET)	s ÖLÇÜSÜ (KALINLIK) s MEASURE (THICKNESS)	Malzeme Material	Kaplama / Coating		
						SN	AG	Nj
TD 2139.80 DP	ERKEKLİ DİŞİ TERMİNAL K.A.6.3 (0.80) =DP=	0.80	0.55±0.1	0.38±0.05	(CuZn30) Pirinç / Brass	-	-	-
TD 2139.80 RP	ERKEKLİ DİŞİ TERMİNAL K.A.6.3 (0.80) =RP=	0.80	0.55±0.1	0.38±0.05	(CuZn30) Pirinç / Brass	-	-	-
TD 2139.80 RPK	ERKEKLİ DİŞİ TERMİNAL K.A.6.3 (0.80) =RPK=	0.80	0.55±0.1	0.38±0.05	(CuZn30) Pirinç / Brass	+	-	-
TD 2139.80 RÇN	ERKEKLİ DİŞİ TERMİNAL K.A.6.3 (0.80) =RÇN=	0.80	0.55±0.1	0.40±0.05	Nikel kaplı çelik / Nickel plated Steel	-	-	+

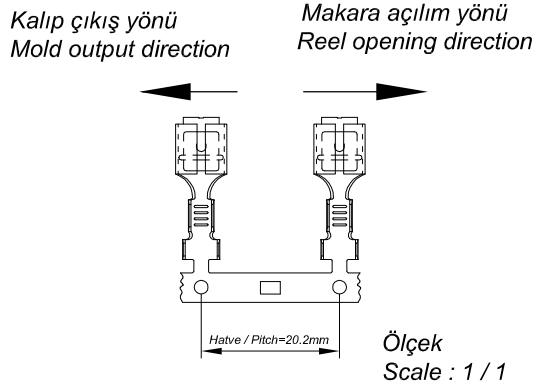

Kablo Kesiti
Wire Section : 0.50 - 1 mm²
Resim üzerinden ölçü almayınız
do not measure on drawing

Perspektif
Perspective

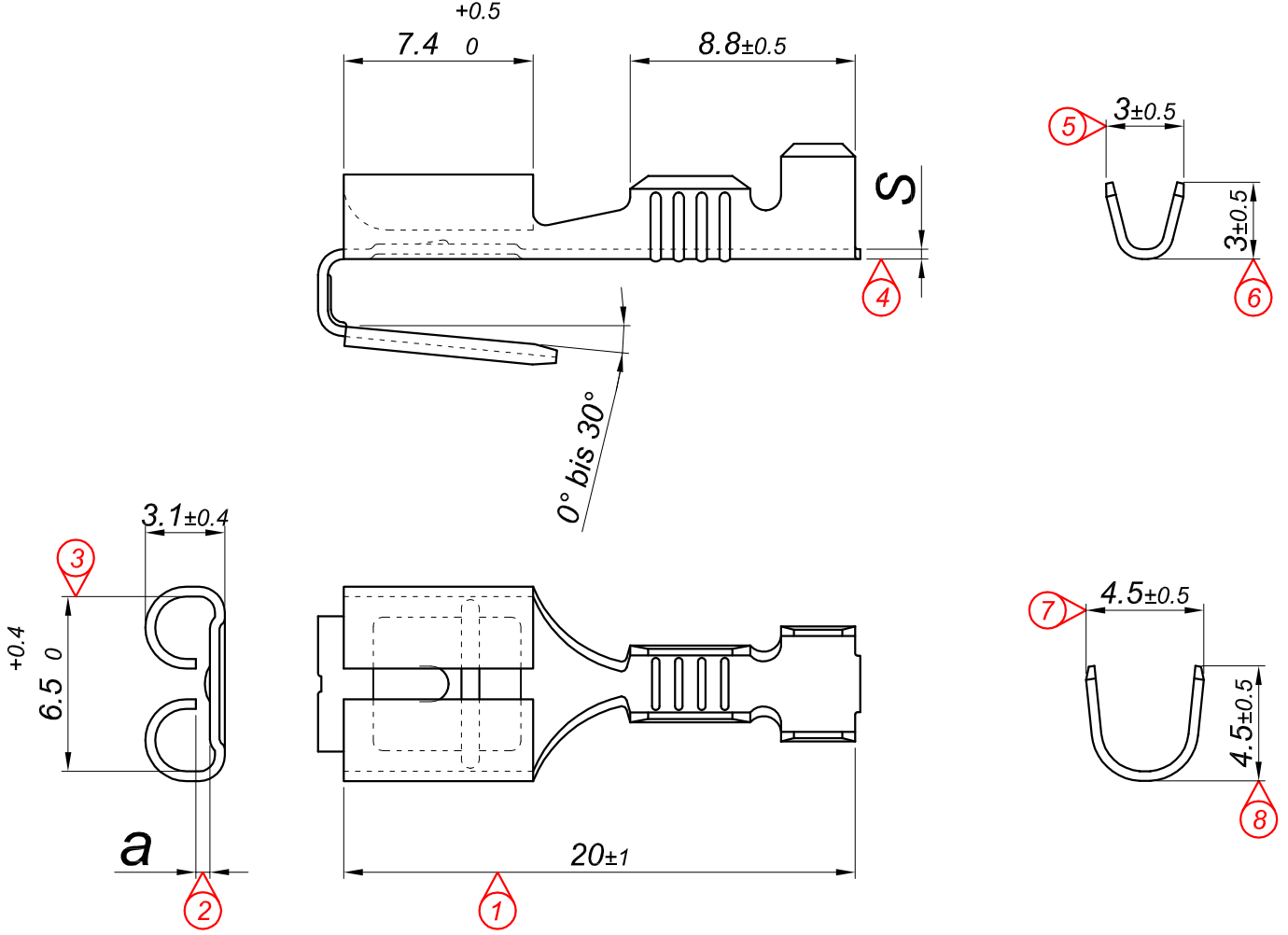
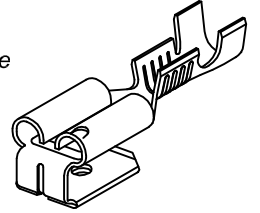

Tarih / Date	16.05.2011	İmza /Signature	Ölçek /Scale			
Çizen / Desing	M.Yağcı					
Onay / Approval	S.Gölcük		4 / 1	No	Değişiklik / Revision	Tarih/Date
		Parça Adı: Part Name	ERKEKLİ DİŞİ FİŞ KÜÇÜK AYAK 6.3		Parça Kodu: Part Code	TD 2139